

### SPECIFICATIONS

Model	P42EMV	
Panel	Screen Size (diagonal)	42"
	Active Display Area (in/mm)	36.62 x 20.60 / 930.24 x 523.26
	Resolution	1920 x 1080
	Aspect Ratio	16:9
	Display Colors	16.7 M
	Brightness (cd/m <sup>2</sup> ; typ.)	450
	Contrast Ratio	1300:1
	Response Time (ms; GTG)	12
	Viewing Angle	178°/178°
	Lifetime (hours)	50,000
	Backlight type	LED
Input	HDMI   VGA(D-SUB)   AV   USB   SD Card	
Power	Input Voltage	100 ~ 240V AC
	Power consumption	110 W
Operation	Temperature (°C)	0 - 40
	Humidity (%)	20 - 80
Dimension	Set (W x H x D), in/mm	37.92 x 21.8 x 1.69 / 963.2 x 553.9 x 43
	Bezel Size (U/D/L/R), in   mm	0.52/0.52/0.57/0.57   13.25/13.25/14.4/14.4
	Wall Mounting (WxH) mm	300 x 300
Weight	Set (kg)	16.7

### FEATURES

#### Special Out-Of-Home LCD Panel

By using commercial grade LCD panels for Out-Of-Home applications, HYUNDAI Digital Signage display can provide higher brightness and contrast than standard LCD TV panels. This guarantees longer working time, deliver clear and bright image contents in the portrait or landscape format without any loss of quality.

#### LED Backlight

HYUNDAI's public displays with LED backlight bring the advantage of up to 40% lower power consumption, compared to displays with CCFL backlight.

#### Slim Design

These products enable the super-slim design.

#### Media Player

Type	Supported file format
Movie	MPEG-2, MPEG-4, WMV, AVI
Photo	JPEG
Music	MP3

### DIMENSIONS [unit: mm]

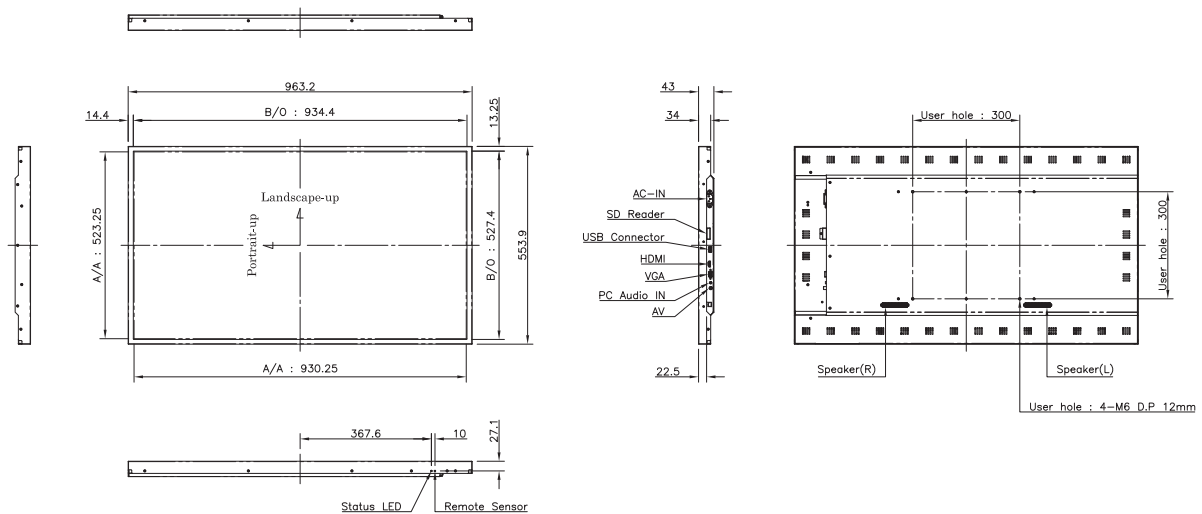

Specifications and design are subject to change without notice. See our website for detailed information.

UPDATE : MAR, 2017